

S.T.G. Germany GmbH

PRODUCT RANGE

GÜNTHER®



Reed Switches

High Voltage Relays

DIL-SIL-Reed Relays

Non-Mercury Tilt Switches

Reed Sensors

Automotive Sensors

Liquid Level Sensors

Acceleration Sensors

Seat Position Sensors

Proximity Sensors

Inclination Sensors

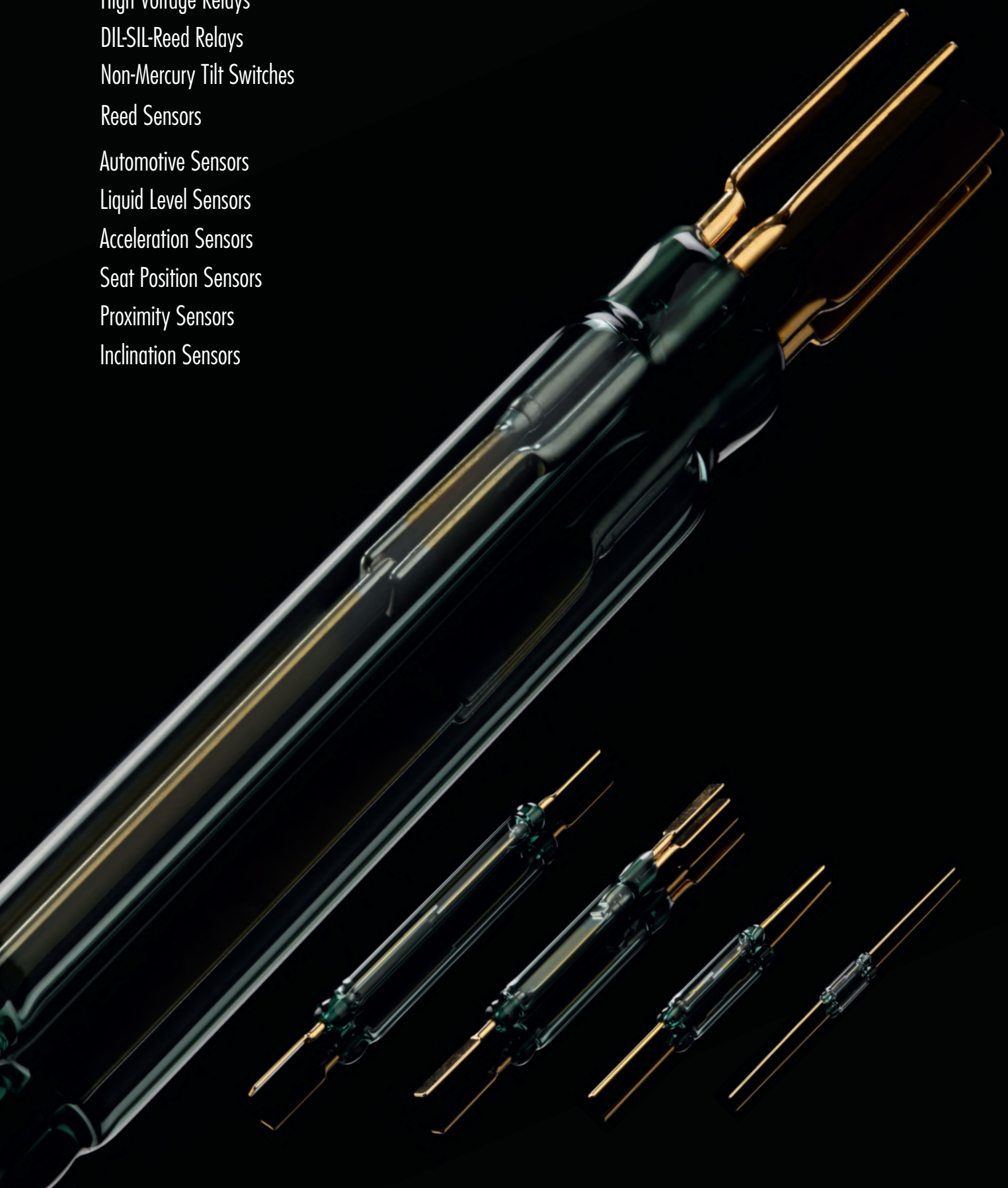



Reed Switches

The quality of our Reed Switches meets the very high international standards.

The variety of the Reed Switch types and the state-of-the-art development enable us to cover almost all industrial applications and specifications.

Our product range is complemented by the Reed Switches of M/S OKI Sensor Device Corporation, with whom we have an „International Distributor Agreement“.

Our Reed Switches are available as normally-open, normally-closed mounted with biasing magnet or bistable versions.

The scope of implementing Reed Switches is far-ranging. Especially when developing new custom applications, there may be the necessity to adapt the Reed Switch geometry to special assembly situations.

By extending, cutting, bending or combinations thereof we gain the ability to customize the Reed Switch lead-outs to meet individual customer requirements.

Since the use of SMT is intensifying especially in industrial applications, our product range also includes SMD and moulded Reed Switches with common connectivity.

For use in automated mounting machines the SMD Reed Switches are also available in Tape & Reel packaging.

Page 4 - 11

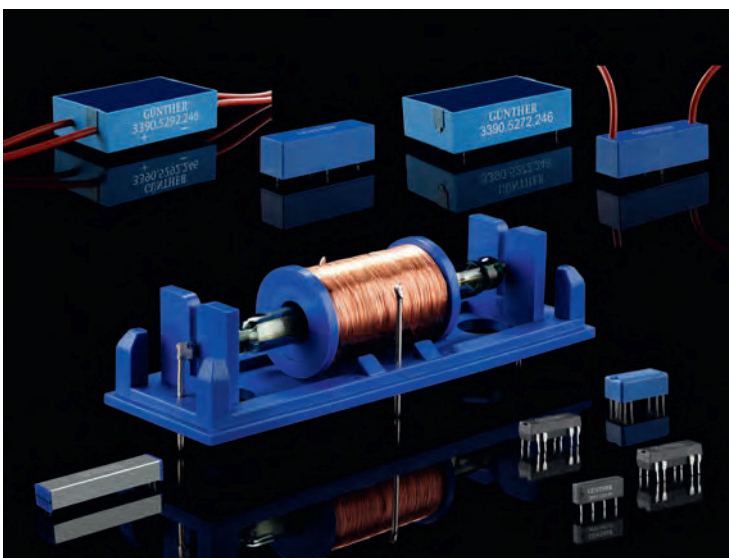

High Voltage Reed Relays

Our High Voltage Reed Relays have outstanding performance characteristics in insulation resistance and stand-off voltage and thus find application in many electronic and electrotechnical areas.

Page 12 - 18

Reed Relays

A wide range of standard Reed Relays and our know-how to develop customer specific Reed Relays allows us to find a solution for almost every application requirement.

Page 19 - 23

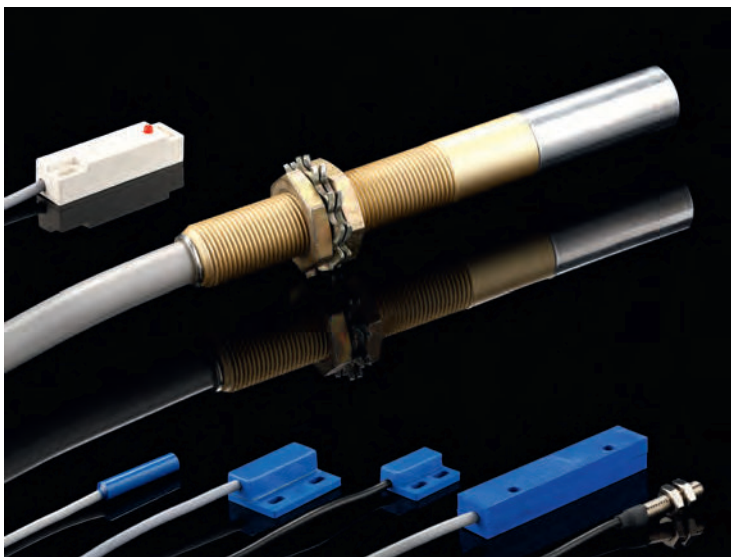

Proximity Sensors

Proximity Sensors are based on Reed Switches which are actuated without direct physical contact. The switching operation is generally triggered by the approach respectively by the removal of a magnetic field.

Proximity Sensors are used in technical processes for position detection of objects and tools, or as signal source for security measures.

Proximity Sensors are implemented when mechanical limit switches are unsuitable due to adverse operating conditions, and when other non-contact switches such as inductive and capacitive sensors are too expensive.

Aside the very good cost/performance ratio our Proximity Sensors stand out due to their multi-purpose applicability. This is obtained by the use of various housing types in combination with diverse connectivity.

Individual solutions can be designed according to customer specifications.

Page 24 - 25



Pendulum / Inclination Sensor

The Pendulum / Inclination Sensor for the measurement of angles enables differential angles above 2°. The Sensor's repetitive accuracy allows its use for very high precision requirements. The patented Sensor replaces former mercury solutions and is used in the automotive industry as well as in other fields of industry and engineering.

Page 26 - 27

Automotive Sensor / ABS Sensor

The Automotive Sensor / ABS Sensor is designed utilizing several Pendulum Sensors. When the preset acceleration is exceeded the Pendulum with the fixed magnet deflects and activates the Reed Switch. The Sensor can be adjusted for accelerations above 0,1g. Other customer specific Automotive Sensors, such as Door Lock Sensors and the like can also be designed.



Acceleration Sensor / Crash Sensor

The Acceleration Sensor / Crash Sensor can detect axial accelerations with an adjustable response value beyond a prespecified g-force (multiple gravitational acceleration). When the prescribed acceleration is exceeded a flying magnet passes a Reed Switch triggering contact.

Typical automotive applications include airbag and seatbelt systems. The Acceleration Sensor can be adjusted for accelerations above 2g to meet preselected customer acceleration requirements as well as other design/package specifications.

Contact Protection

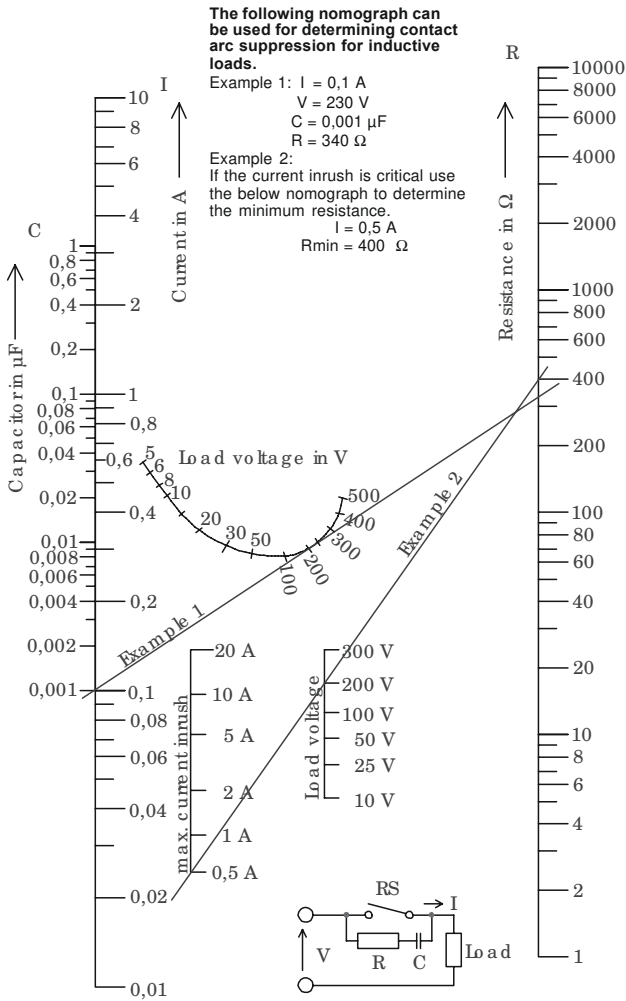

Capacitive Loads

Unlike inductive loads, capacitive and lamp loads are prone to high inrush currents which can lead to faulty operation and even contact welding.

When switching charged capacitors (including cable capacitance) a sudden unloading can occur, the intensity of which is determined by the capacity and length of the connecting leads to the switch. This inrush peak can be reduced by a series of resistors. The value of these resistors is dependent on the particular application but should be as high as possible to ensure that the inrush current is within the allowable limits.

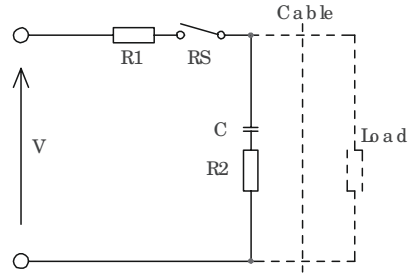

The above diagram illustrates a resistor/capacitor network for protecting a Reed Switch against high inrush currents. R1 and/or R2 are used depending upon circuit conditions.

With lamp load applications it is important to note that cold lamp filaments have a resistance 10 times smaller than already glowing filaments. This means that when being turned on, the lamp filament experiences a current flow 10 times greater than when already glowing. This high inrush current can be reduced to an acceptable level through the use of a series of current-limiting resistors. Another possibility is the parallel switching of a resistor across the switch. This allows just enough current to flow to the filament to keep it warm, yet not enough to make it glow.

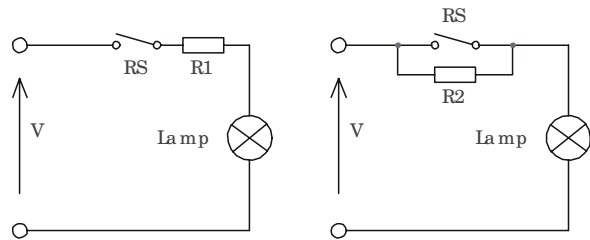

Lamp load with parallel or current limiting resistor across the switch

		NORMALLY OPEN								
		SMD		MOULDED		MICROMINIATURE				
S.T.G. Type		5213	5228	6213	6228	0213	0311	0211	0312	0219
Parameters OKI Type		ORD213S-1	ORD228S-1	RA-903	RA-901	ORD213	ORD311	ORD211	ORD312	ORD219
Contact form		A	A	A	A	A	A	A	A	A
Contact material		Rh	Rh	Rh	Rh	Rh	Ir	Rh	Ir	Rh
Switching capacity	max. W/VA	1	10	1	10	1	10	1	30	10
Switching voltage	max. V AC/DC	24	100	24	100	24	100	24	100	100
Switching current	max. A	0,1	0,5	0,1	0,5	0,1	0,5	0,1	0,5	0,5
Carrying current	max. A	0,3	1,0	0,3	1,0	0,3	1,0	0,3	1,0	1,0
Dielectric strength	min. VDC	150	150	150	200	150	250	150	250	200
Contact resistance	max. mΩ	200	100	200	100	200	200	100	100	100
Insulation resistance	min. Ω	10 ⁹	10 ⁹	10 ⁹	10 ⁹	10 ⁹	10 ⁹	10 ⁹	10 ⁹	10 ⁹
Pull-in sensitivity	AW	10...40*	10...40*	16...46*	16...49*	10...40	10...40	10...40	10...40	10...25
Drop-out sensitivity	min. AW	5	5	10	10	5	5	5	5	5
Switching time without bounce	max. ms	0,3	0,4	0,3	0,4	0,3	0,3	0,3	0,4	0,4
Bounce time	max. ms	0,3	0,3	0,3	0,3	0,3	0,3	0,3	0,3	0,3
Release time	max. ms	0,05	0,05	0,05	0,05	0,05	0,05	0,05	0,05	0,05
Resonant frequency	typ. Hz	11000	5000	13000	5400	11000	13000	7500	5900	5900
Operating frequency	max. Hz	500	500	500	500	500	500	500	500	500
Vibration	20 g Hz	10-1000	10-1000	10-1000	10-1000	10-1000	10-1000	10-1000	10-1000	10-1000
Shock	11 ms g	30	30	30	30	30	30	30	30	30
Capacitance	typ. pF	0,4	0,3	0,4	0,3	0,4	0,4	0,2	0,3	0,3
Operating temperature range	°C	-40 ...+125								
Test coil	Type					0211	0211	0211	0221	0221
Features		Super ultra miniature SMD	Miniature high performance SMD	Ultra miniature SMD	Miniature SMD	Super ultra miniature	Super ultra miniature, long life	Ultra miniature	High power, long life	Miniature high performance

Dimensions

Total length	A max. mm	13,0	20,0	13,0	20,0	36,1	36,1	36,0	45,0	45,0
Glass length	B max. mm	7,0	14,0	8,7	16,2	7,0	7,0	10,0	12,0	12,0
Glass diameter	C max. mm	1,8	2,2	2,2 x 2,2	2,6 x 2,6	1,8	1,8	2,0	2,0	2,0
Wire diameter	D max. mm	0,30	0,50	0,80	0,70	0,30	0,30	0,40	0,50	0,50

Additional types on request

* pre-forming

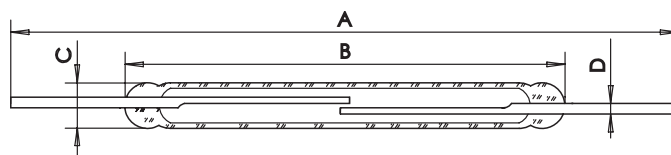

Form A

Actuation of Reed Switches with a Permanent Magnet

Examples of switching with the use of a moving magnet

Direct Actuation:

A magnet moved perpendicularly towards and away from a Reed Switch turns it off and on one time.

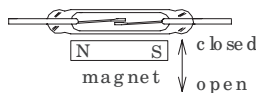

A magnet moved parallel to a Reed Switch operates it from one to three times.

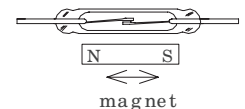

A ring magnet moved parallel to the Reed Switches axis operates it from one to three times.

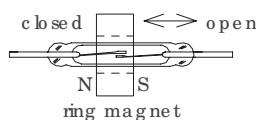

A magnet swung towards and away from a Reed Switch operates it one time.

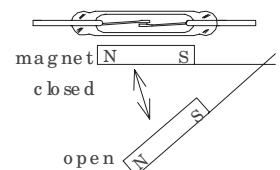

UL / CSA / ETL listed

		NORMALLY OPEN								
		MICROMINIATURE		SUBMINIATURE						
S.T.G. Type		2522	2525	0221	0228	0324	2322	2325	2312	2315
OKI Type				ORD221	ORD228VL	ORD324				
Contact form		A	A	A (Off Set)	A	A	A	A	A	A
Contact material		Rh	Rh	Rh	Rh	Ir	Rh	Rh	Rh	Rh
Switching capacity	max. W/VA	6	6	10	10	10	10	10	10	10
Switching voltage	max. V AC/DC	140	140	100	100	100	150	100	230	230
Switching current	max. A	0,5	0,5	0,3	0,5	0,5	0,5	0,5	0,5	0,5
Carrying current	max. A	0,8	0,8	1,0	1,0	1,0	1,0	1,0	1,0	1,0
Dielectric strength	min. VDC	200	200	150	150	250	200	200	400	400
Contact resistance	max. mΩ	150	150	100	100	100	150	150	150	150
Insulation resistance	min. Ω	10 ¹⁰	10 ¹⁰	10 ⁹	10 ⁹	10 ¹⁰	10 ¹⁰	10 ¹⁰	10 ¹⁰	10 ¹⁰
Pull-in sensitivity	AW	10...40	10...40	10...30	10...40	10...40	10...35	10...35	15...35	15...35
Drop-out sensitivity	min. AW	5	5	5	5	4	5	5	5	5
Switching time without bounce	max. ms	1,0	1,0	0,4	0,4	0,4	1,8	1,8	1,8	1,8
Bounce time	max. ms	0,3	0,3	0,5	0,3	0,3	0,2	0,2	0,2	0,2
Release time	max. ms	0,05	0,05	0,05	0,05	0,05	0,05	0,03	0,05	0,05
Resonant frequency	typ. Hz	6000	6000	2750	5000	5000	5000	5000	5000	5000
Operating frequency	max. Hz	400	400	500	500	500	200	200	200	200
Vibration	20 g Hz	35g/2000	35g/2000	10-1000	10-1000	10-1000	35g/2000	35g/2000	35g/2000	35g/2000
Shock	11 ms g	50	50	30	30	30	50	50	50	50
Capacitance	typ. pF	0,5	0,5	0,3	0,3	0,3	0,7	0,7	0,7	0,7
Operating temperature range	°C	-40...+150		-40...+125			-40...+150			
Test coil	Type	1035	1035	0221	0221	0221	1035	1035	1035	1035
Features		Miniature, high power	Miniature, close differential	Miniature, offset-type	Miniature, high performance, automotive	Miniature, general purpose	Miniature, general purpose	Miniature, general purpose close differential	Miniature, high power	Miniature, high power close differential

Dimensions

Total length	A max.	mm	55,0	55,0	45,0	45,0	45,0	55,0	55,0	55,0	55,0
Glass length	B max.	mm	11,0	11,0	13,0	14,0	14,0	14,1	14,1	14,1	14,1
Glass diameter	C max.	mm	2,1	2,1	2,3	2,2	2,2	2,3	2,3	2,3	2,3
Wire diameter	D max.	mm	0,40	0,40	0,35x0,6	0,50	0,50	0,50	0,50	0,50	0,50

Additional types on request

Form A

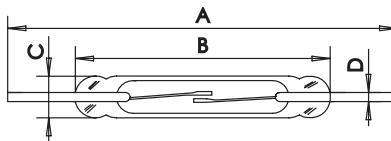

Rotation:

Examples of switching through rotational movement:

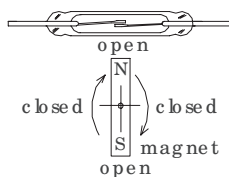
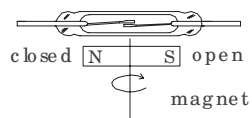

Indirect Actuation: Shielding

With the stationary arrangement of a Reed Switch and magnet, the contact blades are closed. Should the magnetic field be diverted away from the Reed Switch by a shield of ferro-magnetic material placed between the switch and the magnet, the contacts will open. When the shield is removed, the contact blades become magnetically actuated and close.

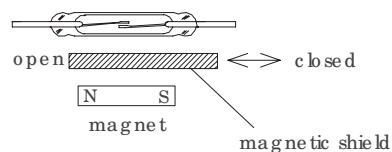

Parameters	S.T.G. Type OKI Type	NORMALLY OPEN									
		SUBMINIATURE				MINIATURE					
		2314	2317	2211	9215	2221	2722	2725	2715	2717	
Contact form		A	A	A	A	A	A	A	A	A	
Contact material		Rh	Rh	Rh	Rh	Rh	Rh	Rh	Rh	Rh	
Switching capacity	max. W/VA	10	10	50	10	10	10	10	10	10	
Switching voltage	max. V AC/DC	400	470	100	100	100	230	230	350	500	
Switching current	max. A	0,5	0,5	0,5 in-rush 3A	0,4	0,3	0,5	0,5	0,5	0,5	
Carrying current	max. A	1,0	1,0	2,5	1,0	1,0	1,0	1,0	1,0	1,0	
Dielectric strength	min. VDC	600	700	200	150	150	400	400	600	1000	
Contact resistance	max. mΩ	150	150	100	100	100	100	100	100	100	
Insulation resistance	min. Ω	10 ¹¹	10 ¹¹	10 ⁹	10 ⁹	10 ⁹	10 ¹¹	10 ¹¹	10 ¹¹	10 ¹¹	
Pull-in sensitivity	AW	15...35	15...35	20...40	10...50	10...30	20...50	20...50	20...50	20...50	
Drop-out sensitivity	min. AW	5	5	8	4	5	5	5	10	5	
Switching time without bounce	max. ms	1,8	1,8	0,6	0,4	1,0	2,0	2,0	2,0	2,0	
Bounce time	max. ms	0,2	0,2	0,4	0,4	1,0	0,5	0,5	1,0	0,5	
Release time	max. ms	0,05	0,05	0,05	0,05	0,05	0,10	0,10	0,10	0,10	
Resonant frequency	typ. Hz	5000	5000	4600	3700	2750	2900	2900	2900	2900	
Operating frequency	max. Hz	200	200	500	500	500	200	200	230	200	
Vibration	20 g Hz	35g/2000	35g/2000	10-1000	10-1000	10-1000	35g/2000	35/2000	2000	2000	
Shock	11 ms g	50	50	30	30	30	50	50	50	50	
Capacitance	typ. pF	0,7	0,7	0,3	0,3	0,3	0,5	0,5	0,5	0,5	
Operating temperature range	°C	-40...+150			-40...+125			-40...+150			
Test coil	Type	1035	1035	0221	0221	0221	1700	1700	1700	1700	
Features		Miniature, high power	Miniature, high power	Lamp load	General purpose, miniature type	General purpose, offset	High power, wide differential	High power	High power	High breakdown voltage	

Dimensions

Total length	A max. mm	55,0	55,0	45,0	45,0	57,0	55,0	55,0	55,0	55,0
Glass length	B max. mm	14,1	14,1	16,5	17,0	13,0	19,0	19,0	19,0	19,0
Glass diameter	C max. mm	2,3	2,3	2,8	2,8	2,3	2,6	2,6	2,6	2,6
Wire diameter	D max. mm	0,50	0,50	0,6	0,5	0,35x0,6	0,55	0,55	0,55	0,55

Additional types on request

Form A

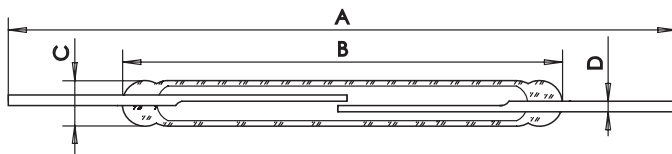

The materials used for Reed Switch magnets are generally ALNICO (an aluminium nickel cobalt alloy), a ceramic (barium ferrite or another metal oxide) or rare earth magnets. Due to their specific magnetic characteristics, the types of magnets differ in shape: ALNICO magnets are bar magnets with a length/diameter ratio of 3/1 to 5/1; oxide magnets are generally disc or moulded magnets. Also important to note is the difference in temperature coefficient: ALNICO: 0.02 %/K, oxide: 0.2 %/K

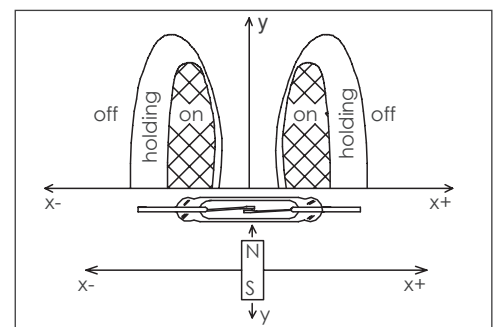
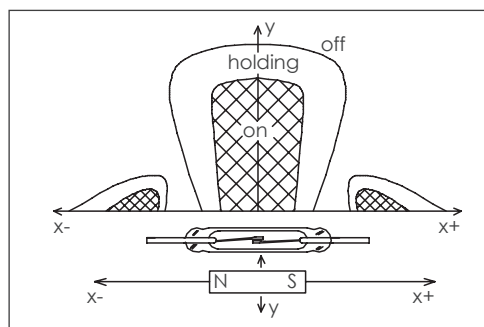
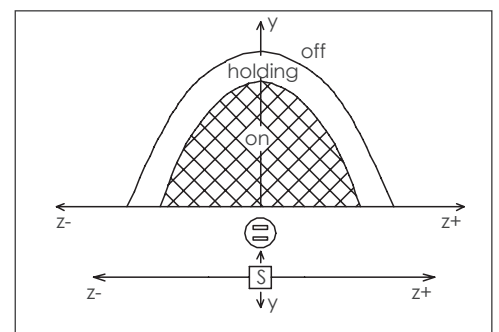

UL / CSA / ETL listed

			NORMALLY OPEN							
			MINIATURE				COMPACT			
			3723	3715	3717	9210	0229	3823	3817	
Parameters	S.T.G. Type	OKI Type				ORD2210V	ORD229			
Contact form			A	A	A	A	A	A	A	
Contact material			Rh	Rh	Rh	Rh	Rh	Rh	Rh	
Switching capacity	max.	W/VA	40	40	40	100	50	60	60	
Switching voltage	max.	V AC/DC	230	230	400	300/350	300	230	400	
Switching current	max.	A	2,0	2,0	2,0	1,0	0,5	3,0	3,0	
Carrying current	max.	A	3,0	3,0	3,0	2,5	2,5	4,0	4,0	
Dielectric strength	min.	VDC	400	500	1000	1000	500	400	850	
Contact resistance	max.	mΩ	80	100	80	100	100	80	80	
Insulation resistance	min.	Ω	10 ¹¹	10 ¹¹	10 ¹¹	10 ¹⁰	10 ¹⁰	10 ¹¹	10 ¹¹	
Pull-in sensitivity		AW	30...70	30...70	30...70	20...60	20...50	30...70	30...70	
Drop-out sensitivity	min.	AW	15	15	15	7	6	15	15	
Switching time without bounce	max.	ms	2,0	2,0	2,0	0,6	0,6	2,5	2,5	
Bounce time	max.	ms	0,5	0,5	0,5	0,5	0,5	0,5	0,5	
Release time	max.	ms	0,10	0,10	0,10	0,05	0,05	0,10	0,10	
Resonant frequency	typ.	Hz	4200	4200	4200	2500	2500	2400	2400	
Operating frequency	max.	Hz	300	300	300	500	500	200	200	
Vibration	20 g	Hz	35g/2000	35g/2000	35g/2000	10-1000	10-1000	35g/1000	35g/1000	
Shock	11 ms	g	50	50	50	30	30	50	50	
Capacitance	typ.	pF	0,5	0,5	0,5	0,5	0,5	0,5	0,5	
Operating temperature range		°C	-40...+150			-40...+125		-40...+150		
Test coil	Type		1700	1700	1700	0221	0221	1800	1800	
Features			High power, close differential	High power	High power	Vacuum, high power	High breakdown voltage	High power, close differential	High power	

Dimensions

Total length	A max.	mm	55,0	55,0	55,0	56,0	56,0	55,0	55,0
Glass length	B max.	mm	19,0	19,0	19,0	21,0	21,0	24,5	24,5
Glass diameter	C max.	mm	2,6	2,6	2,6	2,75	2,75	3,8	3,8
Wire diameter	D max.	mm	0,70	0,70	0,70	0,60	0,60	0,80	0,80

Additional types on request

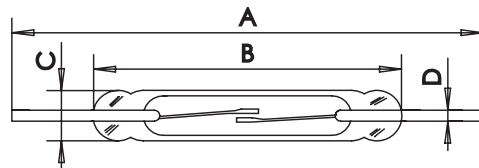

Form A

Life Expectancy:

The life expectancy of a Reed Switch is about 10⁵...10⁶ switching cycles with maximum power. With a low load the life expectancy can reach 5x10⁸ operations. The mechanical life expectancy can reach at least 10⁹ operations. Through the switching of inductive, capacitive and lamp loads, the life expectancy is considerably reduced due to exceeding the specified maximum current.

In General:

For all Reed Switches the standard pull-in sensitivity is given in the table. Other pull-in sensitivities are available on request.

Normally Closed and Bistable Reed Switches:

All Reed Switches are available in a normally closed or bistable version.

Pull-In Sensitivity Tolerance:

The given pull-in sensitivity of the Reed Switch has a test equipment tolerance of ± 2 AT.

			NORMALLY OPEN								
			STANDARD								
Parameters	Type		1517	1515	1513	1525	1520	1523	1565	1595	
Contact form			A	A	A	A	A	A	B	Bistable	
Contact material			Rh	Rh	Rh	Rh	Rh	Rh	Rh	Rh	
Switching capacity	max.	W/VA	30	40	120	80	60/80	120	80	80	
Switching voltage	max.	V AC/DC	1000	800	1000	250	250	250	250	250	
Switching current	max.	A	1,0	1,0	3,0	1,3	1,3	3,0	1,3	1,3	
Carrying current	max.	A	2,0	3,0	5,0	2,0	2,0	5,0	2,0	2,0	
Dielectric strength	min.	VDC	3000	1500	3000	800	800	800	800	800	
Contact resistance	max.	mΩ	80	80	80	80	80	80	80	80	
Insulation resistance	min.	Ω	10 ¹¹	10 ¹¹	10 ¹¹	10 ¹¹	10 ¹¹	10 ¹¹	10 ¹¹	10 ¹¹	
Pull-in sensitivity		AW	75...120	75...120	75...120	75...120	75...120	75...120			
Drop-out sensitivity	min.	AW	25	25	30	25	25	30			
Switching time without bounce	max.	ms	3,5	1,5	3,5	3,5	3,5	3,5	3,5	3,5	
Bounce time	max.	ms	0,5	0,5	0,5	0,5	0,5	0,5	0,5	0,5	
Release time	max.	ms	0,20	0,20	0,20	0,20	0,20	0,20	0,20	0,20	
Resonant frequency	typ.	Hz	900	900	900	900	900	900	900	900	
Operating frequency	max.	Hz	100	100	100	100	100	100	100	100	
Vibration	35 g	Hz	500	500	500	500	500	500	500	500	
Shock	11 ms	g	50	50	50	50	50	50	50	50	
Capacitance	typ.	pF	0,8	0,8	0,8	0,8	0,8	0,8	0,8	0,8	
Operating temperature range		°C	-40...+150								
Test coil	Type		1500	1500	1500	1500	1500	1500			
Features			High break down	High power	High power, lamp load	General purpose	Lamp load	High power, general purpose	Normally closed	Bistable	

Dimensions

Total length	A max.	mm	79	79	79	79	79	79	79	79
Glass length	B max.	mm	52,0	52,0	52,0	52,0	52,0	52,0	52,0	52,0
Glass diameter	C max.	mm	5,4	5,4	5,4	5,4	5,4	5,4	5,4	5,4
Wire diameter	D max.	mm	2,5 x 0,5	2,5 x 0,5	2,5 x 0,5	2,5 x 0,5	2,5x0,5	2,5x0,5	2,5 x 0,5	2,5 x 0,5

Additional types on request

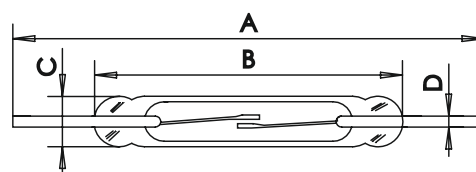

Form A

Test coil type	Length in mm	Outer-ø in mm	Inner-ø in mm	Cu-wire-ø in mm	Number of turns	Nom. resistance Ω
0551	26	16	3,5	0,08	5.000	550
0211	10	11	2,3	0,063	5.000	600
0221	15	11	2,9	0,071	5.000	450
1035	13	14	2,6	0,063	10.000	1.650
1500	48,2	14,2	5,7	0,09	10.000	1.000
1700	20,5	14	2,65	0,08	10.000	1.000
1800	23	15	3,8	0,08	10.000	1.000
6500	28	16	5,8	0,07	10.000	1.490

UL and CSA listed

			CHANGE OVER					
			SUBMINIATURE					
S.T.G. Type			0551	0651	3325	3425	3336	3436
OKI Type			ORT551	ORT551-1				
Contact form			C	C	C	C	C	C
Contact material			Rh	Rh	Rh	Rh	Rh	Rh
Switching capacity	max. W/VA		3	3	5	5	20	20
Switching voltage	max. V AC/DC		30	30	100	100	150	150
Switching current	max. A		0,2	0,2	0,5	0,5	1,0	1,0
Carrying current	max. A		0,5	0,5	1,0	1,0	2,0	2,0
Dielectric strength	min. VDC		150	150	200	200	200	200
Contact resistance	max. mΩ		100	100	150	150	150	150
Insulation resistance	min. Ω		10 ⁹	10 ⁹	10 ⁹	10 ⁹	10 ⁹	10 ⁹
Pull-in sensitivity	AW		10...30	10...30*	15...40	15...40*	15...40	15...40*
Drop-out sensitivity	min. AW		4	4	8	8	5	5
Switching time without bounce	max. ms		1,0	1,0	2,0	2,0	2,0	2,0
Bounce time	max. ms		1,5	1,5	0,6	0,6	0,6	0,6
Release time	max. ms		0,5	0,5	0,02	0,02	0,02	0,02
Resonant frequency	typ. Hz		6000	6000	-	-	-	-
Operating frequency	max. Hz		200	200	250	250	250	250
Vibration	35 g Hz		20g/1000	20g/1000	2000	2000	1000	1000
Shock	11 ms g		30	30	50	50	50	50
Capacitance	typ. pF		1,5	1,5	0,8	0,8	0,8	0,8
Operating temperature range	°C		-40...+125	-40...+125	-40...+150			
Test coil	Type		0551		1035		1035	
Features			Miniature general purpose	0551 with cropped N.C. contact	Miniature general purpose	3325 with cropped N.C. contact	Miniature high power	3336 with cropped N.C. contact

Dimensions

Total length	A max.	mm	56,5	56,5	55	55	55	55
Glass length	B max.	mm	14,0	14,0	14,0	14,0	14,0	14,0
Glass diameter	C max.	mm	2,54	2,54	2,3	2,3	2,3	2,3
Wire diameter	D max.	mm	0,5	0,5	0,35 x 0,75	0,35 x 0,75	0,35 x 0,75	0,35 x 0,75

Additional types on request

* pre-forming

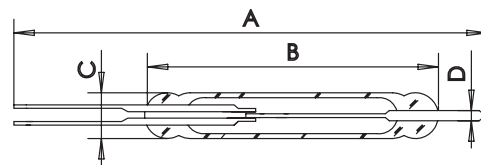

Form C

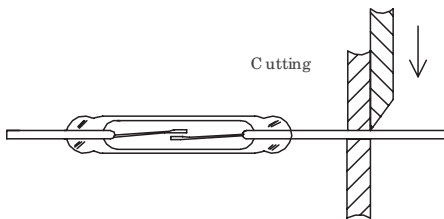

Cutting

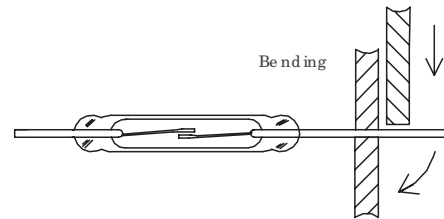

Bending

Cutting and Bending

As the Reed Switch blades are part of the magnetic circuit of a Reed Switch, shortening the leads results in increased pull-in and drop-out values.

When cutting or bending Reed Switches, it is important that the glass body not be damaged. Therefore, the cutting or bending point should be no closer than 3 mm to the glass body.

			CHANGE OVER								
			COMPACT				STANDARD				
Parameters	Type		1925	1915	1917	1965	1995	1620	1625	1665	1695
Contact form			C	C	C	B	Bistable	C	C	B	Bistable
Contact material			Rh	Rh	Rh	Rh	Rh	Rh	Rh	Rh	Rh
Switching capacity	max.	W/VA	60	60	60	60	60	60	60	60	60
Switching voltage	max.	V AC/DC	140	250	400	140	140	230	230	230	230
Switching current	max.	A	1,0	1,0	1,0	1,0	1,0	1,0	1,0	1,0	1,0
Carrying current	max.	A	2,0	2,0	2,0	2,0	2,0	2,0	2,0	2,0	2,0
Dielectric strength	min.	VDC	250	500	1000	250	250	400	400	400	400
Contact resistance	max.	mΩ	100	100	100	100	100	100	100	100	100
Insulation resistance	min.	Ω	10 ⁹	10 ⁹	10 ⁹	10 ⁹	10 ⁹	10 ⁹	10 ⁹	10 ⁹	10 ⁹
Pull-in sensitivity		AW	50...100	50...100	50...100			80...120	80...120		
Drop-out sensitivity	min.	AW	20	20	20			20	20		
Switching time without bounce	max.	ms	4,0	4,0	4,0	4,0	4,0	4,0	4,0	4,0	4,0
Bounce time	max.	ms	0,5	0,5	0,5	0,5	0,5	0,5	0,5	0,5	0,5
Release time	max.	ms	0,15	0,15	0,15	0,15	0,15	0,10	0,10	0,10	0,10
Resonant frequency	typ.	Hz	-	-	-	-	-	-	-	-	-
Operating frequency	max.	Hz	100	100	100	100	100	100	100	100	100
Vibration	35 g	Hz	2000	2000	2000	2000	2000	500	500	500	500
Shock	11 ms	g	50	50	50	50	50	50	50	50	50
Capacitance	typ.	pF	1,0	1,0	1,0	1,0	1,0	1,0	1,0	1,0	1,0
Operating temperature range		°C	-40...+150								
Test coil	Type		1500	1500	1500			1500	1500		
Features			General purpose	High power	High power	Normally closed	Bistable	Long life	General purpose	Normally closed	Bistable

Dimensions

Total length	A max.	mm	70	70	70	70	70	81	81	81	81
Glass length	B max.	mm	36,0	36,0	36,0	36,0	36,0	52,0	52,0	52,0	52,0
Glass diameter	C max.	mm	5,6	5,6	5,6	5,6	5,6	5,6	5,6	5,6	5,6
Wire diameter	D max.	mm	2,5 x 0,5	2,5 x 0,5	2,5 x 0,5	2,5 x 0,5	2,5 x 0,5	2,5 x 0,5	2,5 x 0,5	2,5 x 0,5	2,5 x 0,5

Additional types on request

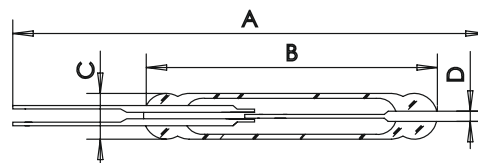

Form C

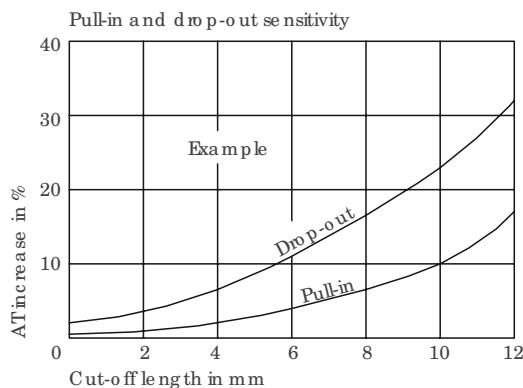

Approvals:

Under ETL No. 3105897 (conforms to UL Std. 508 / certified to CAN/CSA Std. C22.2 No. 14) listed reed switches:

1513, 1515, 1517, 1520, 1523, 1525, 1565, 1595, 1620, 1623, 1625, 1665, 1695, 1915, 1917, 1925, 1965, 1995, 2312, 2314, 2315, 2317, 2322, 2325, 2522, 2525, 2715, 2717, 2722, 2725, 3325, 3336, 3425, 3436, 3715, 3717, 3723, 3817, 3823.

Under UL-No.: E70063 and CSA-No.: LR86615 approved Reed Switches:

0211, 0213, 0221, 0228, 0219, 2211, 2212, 0229, 9210, 0234, 0233, 0551, 0324, 2221.

Introduction

GÜNTHER[®] High Voltage Reed Relay technology is based upon our extensive experience in the design and manufacture of Reed Switches and Reed Relays.

GÜNTHER[®] High Voltage Reed Relays have outstanding performance characteristics in insulation resistance and stand-off voltage. The high dielectric stand-off voltage between the open contacts as well as the high switching voltage are achieved by using high vacuum Reed Switches. A proven assembly and potting technique assures the following relay characteristics:

- Stand-off voltage across open contacts from **3 KV** up to **14 KV** max.
- Stand-off voltage between coil and contact from **10 KV** up to **25 KV** max.
- Switching voltage from **1.5 KV** up to **10 KV** max.

GÜNTHER[®] High Voltage Reed Relays are offered in a variety of contact configurations:

- **1 N.O., 2 N.O.** or **4 N.O.** contacts (normally open contacts)
- **1 N.C.** (normally closed contact)
- **1 N.C. / 1 N.O.** (1 normally closed contact/ 1 normally open contact)

GÜNTHER[®] High Voltage Reed Relays offer mounting flexibility enabling the customer to match different application requirements:

- Coil and Reed Switch connecting pins in the base plate for PCB mounting.
- Coil connecting pins in the base plate for PCB mounting and Reed Switch connections with cable.
Cable length: standard 200 mm
- Coil connecting pins in the base plate for PCB mounting and Reed Switch connecting pins on top of the relay.

GÜNTHER[®] High Voltage Reed Relays have additional features:









- Immunity against harsh environmental conditions (eg. high humidity) by using hermetically sealed switching contacts potted in a strong plastic case.
- High shock and vibration resistance.
- Low contact capacitance and high switching frequency in comparison with electro-mechanical, open relay contacts.
- Washable and resistant to standard automatic cleaning methods.

GÜNTHER[®] High Voltage Reed Relays find application in many areas of the electrotechnical and electronic industry:

- Electronic medical equipment
- Cable tester arrays and cable test equipment
- Copy machines
- Laser optical systems and infra-red equipment
- Test equipment

HIGH VOLTAGE REED RELAYS

Standard Types - Selection Chart

	<p>1270 Number of contacts: 1 contact Contact form: 1 normally open Coil and Reed Switch terminals: Soldering pins on bottom</p> <p>4270 See type 1270 Contact form: 1 normally closed</p>
	<p>1280 Number of contacts: 1 contact Contact form: 1 normally open Coil terminals: Soldering pins on bottom Reed Switch terminals: Soldering pins on top</p> <p>4280 See type 1280 Contact form: 1 normally closed</p>
	<p>1290 Number of contacts: 1 contact Contact form: 1 normally open Coil terminals: Soldering pins on bottom Reed Switch terminals: High voltage cable on top</p> <p>4290 See type 1290 Contact form: 1 normally closed</p>
	<p>1272 Number of contacts: 2 contacts Contact form: 2 normally open Coil terminals: Soldering pins on bottom Reed Switch terminals: Switch 1: soldering pins on bottom Switch 2: soldering pins on top</p>
	<p>1274 Number of contacts: 4 contacts Contact form: 4 normally open Coil and Reed Switch terminals: Soldering pins on bottom</p>
	<p>1294 See type 1274 Reed Switch terminals: High voltage cable at sides</p>
	<p>5272 Number of contacts: 2 contacts Contact form: 1 normally open / 1 normally closed Coil and Reed Switch terminals: Soldering pins on bottom</p>
	<p>5292 See type 5272 Reed Switch terminals: High voltage cable at sides</p>

HIGH VOLTAGE REED RELAYS

CONTACT FORM	1 NORMALLY OPEN											
Type	3316	3390	3391	3392	3316	3390	3391	3392	3316	3390	3391	3392
	1270	1270	1270	1270	1280	1280	1280	1280	1290	1290	1290	1290
Data	.. 6	.. 6	.. 6	.. 6	.. 6	.. 6	.. 6	.. 6	.. 6	.. 6	.. 6	.. 6

Contact Parameters

Switching voltage	max. VAC _{peak}	1.500	5.000	7.500	10.000	1.500	5.000	7.500	10.000	1.500	5.000	7.500	10.000
Dielectric strength	min. VDC	3.000	7.000	10.000	14.000	3.000	7.000	10.000	14.000	3.000	7.000	10.000	14.000
Switching capacity	max. W	30	50	50	50	30	50	50	50	30	50	50	50
Switching current	max. A	1	3	3	3	1	3	3	3	1	3	3	3
Carrying current	max. A	2	5	5	5	2	5	5	5	2	5	5	5
Contact resistance	max. mΩ	80	250	250	250	80	250	250	250	80	250	250	250

Coil Parameters

Nominal coil voltage	VDC	5	12	24	5	12	24	5	12	24
Pull-in voltage	max. VDC	4	10	20	4	10	20	4	10	20
Drop-out voltage	min. VDC	1	2	4	1	2	4	1	2	4
Operating voltage	max. VDC	8	18	36	8	18	36	8	18	36
Coil resistance	+/-15 % Ω	35	200	720	35	200	720	35	200	720

Relay Parameters

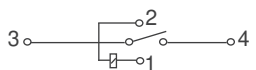
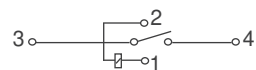
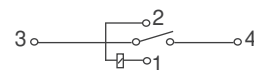
Dielectric strength coil/contact	VDC	20.000	20.000	20.000
Dielectric strength contact/contact	VDC	-	-	-
Insulation resistance coil/contact	Ω	1 x 10 ⁹	1 x 10 ⁹	1 x 10 ⁹
Storage temperature	°C	-35...+90	-35...+90	-35...+90
Operating temperature	°C	-20...+70	-20...+70	-20...+70
Pull-in time incl. bounce	ms	3,5	3,5	3,5
Drop-out time	ms	1,5	1,5	1,5
Dimensions	page	18	18	18
Weight approx.	g	55	55	65
Pin configuration				

Switches with contact code 90-92 are tungsten-plated and should be used only for switching power above approx. 10 mW.

General Parameters

All characteristics for pull-in voltage, drop-out voltage and coil resistance at 20°C +/-3°C ambient temperature. For other temperatures see diagram "temperature range".

Contact Resistance

Initial value at nominal voltage measured by the Kelvin test method at 20V/100mA.

Soldering

During soldering make sure no mechanical stress is applied to terminals because the thermoplastic moulding material might be damaged.

Order Example:

Product group **33 92**
 Contact code **1270**
 Standard type **05**
 Version **6**
 Nominal coil voltage
 05 = 5V
 12 = 12V
 24 = 24V

Insulation Resistance

The insulation resistance is measured with a Tera Ohmmeter at 500V DC. The ambient climate is 20°C +/-3°C and 50 % relative humidity.

Switching Voltage, Switching Current and Power Rating

The listed values for switching voltage, switching current and power rating are absolute limits. If any of these values is exceeded, a reduction of life expectancy will result (see following power diagram).

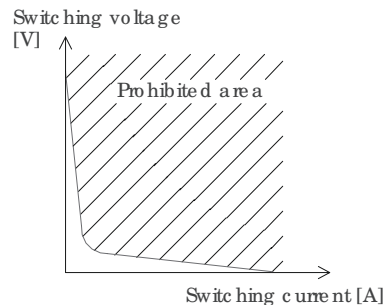

HIGH VOLTAGE REED RELAYS

CONTACT FORM	2 NORMALLY OPEN				4 NORMALLY OPEN							
Type	3316	3390	3391	3392	3316	3390	3391	3392	3316	3390	3391	3392
	1272	1272	1272	1272	1274	1274	1274	1274	1294	1294	1294	1294
Data	.. 6	.. 6	.. 6	.. 6	.. 6	.. 6	.. 6	.. 6	.. 6	.. 6	.. 6	.. 6

Contact Parameters

Switching voltage	max. VAC _{peak}	1.500	5.000	7.500	10.000	1.500	5.000	7.500	10.000	1.500	5.000	7.500	10.000
Dielectric strength	min. VDC	3.000	7.000	10.000	14.000	3.000	7.000	10.000	14.000	3.000	7.000	10.000	14.000
Switching capacity	max. W	30	50	50	50	30	50	50	50	30	50	50	50
Switching current	max. A	1	3	3	3	1	3	3	3	1	3	3	3
Carrying current	max. A	2	5	5	5	2	5	5	5	2	5	5	5
Contact resistance	max. mΩ	80	250	250	250	80	250	250	250	80	250	250	250

Coil Parameters

Nominal coil voltage	VDC	5	12	24	5	12	24	5	12	24
Pull-in voltage	max. VDC	4	10	20	4	10	20	4	10	20
Drop-out voltage	min. VDC	0,5	1,2	2,4	0,5	1	1	0,5	1	2
Operating voltage	max. VDC	7	16	29	7,5	14,5	27	7,5	14,5	27
Coil resistance	+/-15 % Ω	15	85	275	12	42	175	12	42	175

Relay Parameters

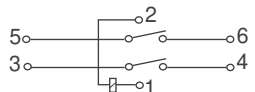
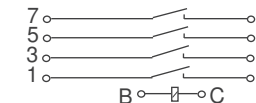
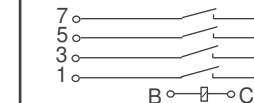
Dielectric strength	coil/contact	VDC	10.000	10.000	10.000
Dielectric strength	contact/contact	VDC	10.000	8.000	8.000
Insulation resistance	coil/contact	Ω	1 x 10 ⁹	1 x 10 ⁹	1 x 10 ⁹
Storage temperature	°C	-35...+90	-35...+90	-35...+90	
Operating temperature	°C	-20... +70	-20... +70	-20... +70	
Pull-in time incl. bounce	ms	3,5	3,5	3,5	
Drop-out time	ms	1,5	1,5	1,5	
Dimensions	page	18	18	18	
Weight	approx. g	55	130	140	
Pin configuration					

Switches with contact code 90-92 are tungsten-plated and should be used only for switching power above approx. 10 mW.

Dielectric Strength

Tested in a radiation (e.g. light, x-ray) free environment by applying a DC voltage across the open contacts, between adjacent contacts and between coil and contact. The trigger current is 100 μA. The unused contacts should not be connected during the test.

Switching Time

Pull-in time including bounce time at nominal voltage and 20 Hz: 1,5 ... 3,5 ms

Release time (without diode) at nominal voltage and 20 Hz: 0,4 ... 1,5 ms

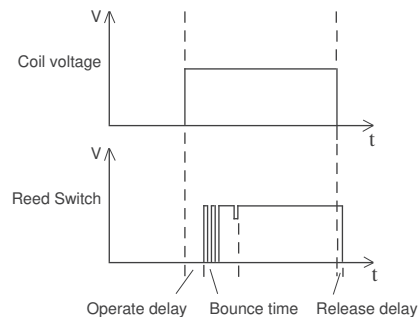

Contact Capacitance (Typical Values)

Die Kapazitätswerte gelten als typische Werte.

Capacitance:	N.O.
Across open contacts	0,8 - 1,2 pF
Between open contacts and coil	1,4 - 2,2 pF
Between closed contacts and coil	2,3 - 3,5 pF

HIGH VOLTAGE REED RELAYS

CONTACT FORM	1 NORMALLY CLOSED + 1 NORMALLY OPEN							
Type	3316	3390	3391	3392	3316	3390	3391	3392
	5272	5272	5272	5272	5292	5292	5292	5292
Data	.. 6	.. 6	.. 6	.. 6	.. 6	.. 6	.. 6	.. 6

Contact Parameters

Switching voltage	max.	VAC _{peak}	1.500	5.000	7.500	10.000	1.500	5.000	7.500	10.000
Dielectric strength	min.	VDC	3.000	7.000	10.000	14.000	3.000	7.000	10.000	14.000
Switching capacity	max.	W	30	50	50	50	30	50	50	50
Switching current	max.	A	1	3	3	3	1	3	3	3
Carrying current	max.	A	2	5	5	5	2	5	5	5
Contact resistance	max.	mΩ	80	250	250	250	80	250	250	250

Coil Parameters

Nominal coil voltage	VDC	5	12	24	5	12	24
Pull-in voltage	max. VDC	4	10	20	4	10	20
Drop-out voltage	min. VDC	0,5	1	2	0,5	1	2
Operating voltage	max. VDC	7,5	14,5	27	7,5	14,5	27
Coil resistance	+/-15 % Ω	27	135	345	27	135	345

Relay Parameters

Dielectric strength	coil/contact	VDC	10.000	10.000
Dielectric strength	contact/contact	VDC	8.000	8.000
Insulation resistance	coil/contact	Ω	1 x 10 ⁹	1 x 10 ⁹
Storage temperature	°C	-35...+90	-35...+90	
Operating temperature	°C	-20... +70	-20... +70	
Pull-in time incl. bounce	ms	3,5	3,5	
Drop-out time	ms	1,5	1,5	
Dimensions	page	18	18	
Weight	approx. g	130	140	
Pin configuration				

Switches with contact code 90-92 are tungsten-plated and should be used only for switching power above approx. 10 mW.

Life Expectancy

The life expectancy of a Reed Relay is at least 10⁵...10⁶ operations at nominal load. At minimum load the life expectancy can endure up to 5 x 10⁸ operations. The mechanical life expectancy is 10⁹ operations (minimum).

Through the switching of higher loads, especially inductive or capacitive and lamp loads, life expectancy can be considerably reduced due to exceeding the permissible maximum current.

Proper contact protection will reduce electromagnetic interference and rapid contact erosion. Suppressing diodes in connection with inductive loads may cause extreme contact wear.

Shock and Vibration

During shock and vibration tests the relays must be energized with nominal voltage. The contact should not open or close longer than 10 μs.

Vibration stability: 20 g/50 ... 500 Hz

Shock stability: 35 g/11 ms half sine wave.

HIGH VOLTAGE REED RELAYS

CONTACT FORM	1 NORMALLY CLOSED											
Type	3316	3390	3391	3392	3316	3390	3391	3392	3316	3390	3391	3392
	4270	4270	4270	4270	4280	4280	4280	4280	4290	4290	4290	4290
Data	..6	..6	..6	..6	..6	..6	..6	..6	..6	..6	..6	..6

Contact Parameters

Switching voltage	max. VAC _{peak}	1.500	5.000	7.500	10.000	1.500	5.000	7.500	10.000	1.500	5.000	7.500	10.000
Dielectric strength	min. VDC	3.000	7.000	10.000	14.000	3.000	7.000	10.000	14.000	3.000	7.000	10.000	14.000
Switching capacity	max. W	30	50	50	50	30	50	50	50	30	50	50	50
Switching current	max. A	1	3	3	3	1	3	3	3	1	3	3	3
Carrying current	max. A	2	5	5	5	2	5	5	5	2	5	5	5
Contact resistance	max. mΩ	80	250	250	250	80	250	250	250	80	250	250	250

Coil Parameters

Nominal coil voltage	VDC	5	12	24	5	12	24	5	12	24
Pull-in voltage	max. VDC	4	10	20	4	10	20	4	10	20
Drop-out voltage	min. VDC	0,5	1	2	0,5	1	2	0,5	1	2
Operating voltage	max. VDC	6,5	14,5	27	6,5	14,5	27	6,5	14,5	27
Coil resistance	+/-15 % Ω	50	400	675	50	400	675	50	400	675

Relay Parameters

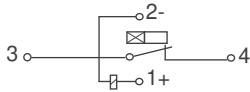
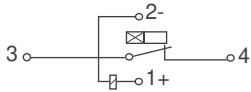
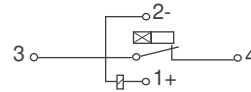
Dielectric strength	coil/contact	VDC	20.000	20.000	20.000
Dielectric strength	contact/contact	VDC	-	-	-
Insulation resistance	coil/contact	Ω	1 x 10 ⁹	1 x 10 ⁹	1 x 10 ⁹
Storage temperature		°C	-35...+ 90	-35...+ 90	-35...+ 90
Operating temperature		°C	-20...+ 70	-20...+ 70	-20...+ 70
Pull-in time incl. bounce		ms	3,5	3,5	3,5
Drop-out time		ms	1,5	1,5	1,5
Dimensions		page	18	18	18
Weight	approx.	g	55	55	65
Pin configuration					

Switches with contact code 90-92 are tungsten-plated and should be used only for switching power above approx. 10 mW.

Operating Temperature

The operating temperature is the internal temperature of the relay (ambient temperature plus self heating). If relays are operating at higher ambient temperatures (ϑ_a) than + 20 °C, the pull-in voltage and the maximum coil voltage must be calculated as follows:

Pull-in voltage = Pull-in voltage at 20 °C x k1

Maximum coil voltage = Max. coil voltage at 20 °C x k2

When mounting relays side by side a gap of approximately half the relay-width is recommended to avoid mutual magnetic influence.

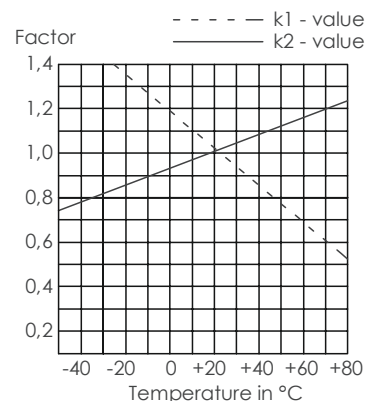

HIGH VOLTAGE REED RELAYS

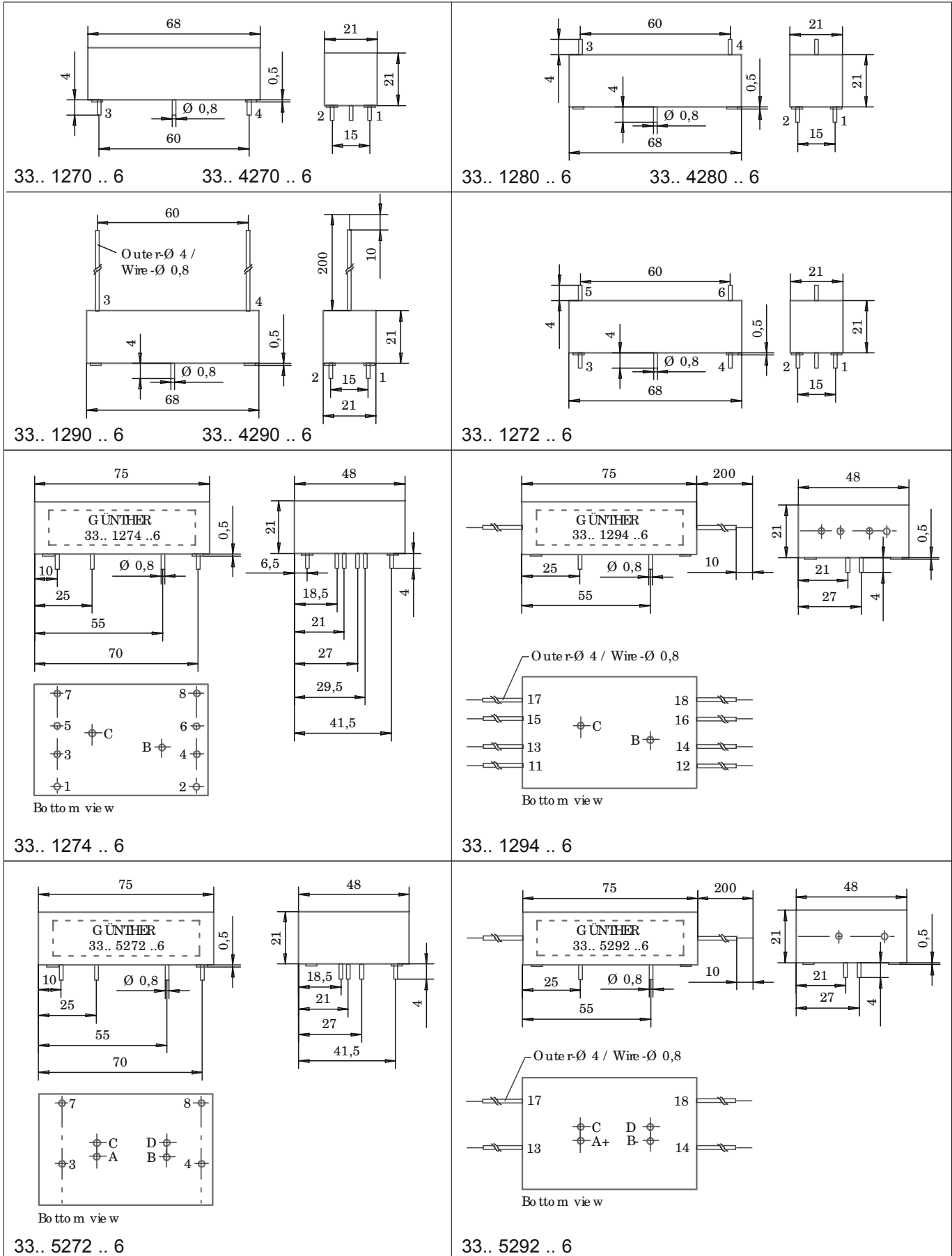

Dimensions in mm

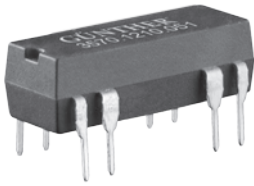

Version	DIL-High Profile		
Contact Form	1 Normally Open	2 Normally Open	1 Change Over
Type	3570 1210 ...	3572 1220 ...	3563 1231 ...
Features	- Industry-standard housing	- Industry-standard housing	- Industry-standard housing

Coil Parameters

		VDC	5	12	24	5	12	24	5	12	24
Nominal coil voltage		VDC	5	12	24	5	12	24	5	12	24
Pull-in voltage	max.	VDC	3,8	9	18	3,8	9	18	3,8	9	18
Drop-out voltage	min.	VDC	0,8	1	2	0,8	1	2	1	2	4
Operating voltage	max.	VDC	20	30	40	10	20	40	10	18	35
Coil resistance	±10%	Ω	500	1000	2150	140	500	2150	200	500	2150

Contact Parameters

		W/VA	10	10	3
Switching voltage	max.	W/VA	10	10	3
Dielectric strength	max.	V	100 AC/DC	100 AC/DC	70 AC / 100 DC
Switching capacity	max.	A	0,5	0,5	0,25
Switching current	max.	A	1,0	1,0	0,5
Carrying current	max.	mΩ	150	150	200
Contact resistance	min.	VDC	200	200	140

Relay Parameters

Dielectric strength	coil/contact	VDC	1000	1000	1000
Insulation resistance	coil/contact	Ω	10 ¹⁰	10 ¹⁰	10 ¹⁰
Storage temperature		°C	-40...+105	-40...+105	-40...+105
Operating temperature		°C	-35...+80	-35...+80	-35...+80
Pull-in time incl. bounce		ms	0,5	0,5	2,0
Drop-out time		ms	0,5	0,5	3,0
Dimensions		page	21	21	21
Weight		approx. g	2,3	2,3	2,3
Pin configuration (top view)					

General Parameters

Life Expectancy

The life expectancy of a Reed Relay is at least 10⁵...10⁶ operations at nominal load. At minimum load the life expectancy can be up to 5 x 10⁸ operations.

The mechanical life expectancy is 10⁹ operations (minimum).

Through the switching of higher loads, especially inductive or capacitive and lamp loads, life expectancy can be considerably reduced due to exceeding the permissible maximum current.

Order Example:

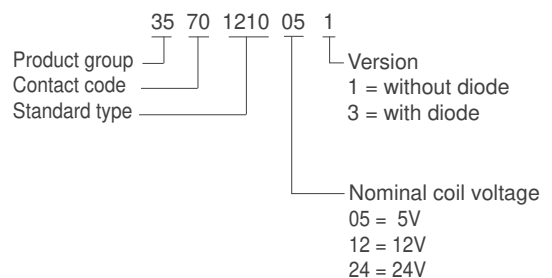

DIL-SIL-REED RELAYS

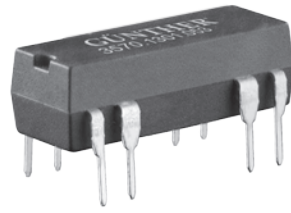

Version	DIL-Low Profile	SIL
Contact Form	1 Normally Open	1 Normally Open
Type	3570 1301 ...	3570 1331 ...
Features	- Industry-standard	- Industry-standard

Coil Parameters

Nominal coil voltage	VDC	5	12	24	5	12	24
Pull-in voltage	max. VDC	3,8	9	18	3,8	9	18
Drop-out voltage	min. VDC	0,8	1	2	0,8	1,5	2
Operating voltage	max. VDC	15	20	30	15	30	40
Coil resistance	±10% Ω	500	1000	2000	500	1000	2000

Contact Parameters

Switching capacity	max. W/VA	10	10
Switching voltage	max. V	100 AC/DC	100 AC/DC
Switching current	max. A	0,5	0,5
Carrying current	max. A	1,0	1,0
Contact resistance	max. mΩ	150	150
Dielectric strength	min. VDC	200	200

Relay Parameters

Dielectric strength	coil/contact VDC	1000	1000
Insulation resistance	coil/contact Ω	10 ¹⁰	10 ¹⁰
Storage temperature	°C	-40...+105	-40...+105
Operating temperature	°C	-35...+80	-35...+80
Pull-in time incl. bounce time	max. ms	0,5	0,5
Drop-out time with diode	ms	0,5	0,5
Dimensions	page	21	21
Weight	approx. g	1,8	1,6
Pin configuration (top view)			

Vibration and Shock Resistance

During the evaluation of vibration and shock resistance, the relays are driven with nominal voltage. The switches should not open longer than 10 µsec.

	Normally Open	Change Over
Vibration resist.	20 g / 5...2000 Hz	10 g / 5...500 Hz
Shock resistance	100 g / 11 ms Sine half wave	50 g / 11 ms Sine half wave

Washability

Resistant to Caltron, Freon, alcohol and distilled (pure) water. During the final rinsing phase only the purest substances should be used.

Capacitance

The capacitance parameters are regarded as typical and are calculated for versions without shielding:

Capacitance, measured...	N.O.	Change Over
across open contact	0,8 pF	2,5 pF
between open contact and coil	1,5 pF	2,5 pF
between closed contact and coil	3,0 pF	2,5 pF

Solderability

By using laser welding in manufacture, a number of our DIL-SIL-Reed Relays are suitable for enhanced soldering requirements.

Hole Diameter in PCB: Ø 0,65 mm

DIL-High Profile

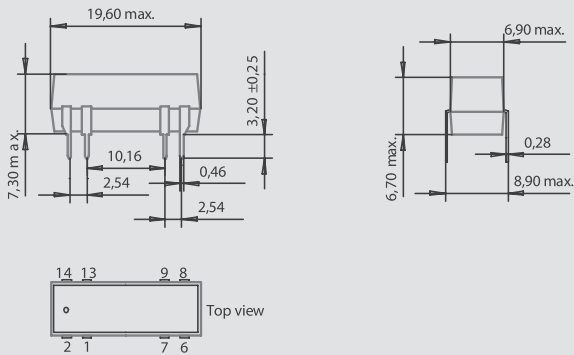

DIL-Low Profile

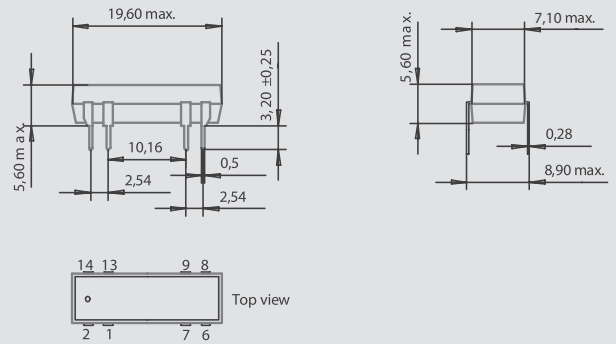

SIL

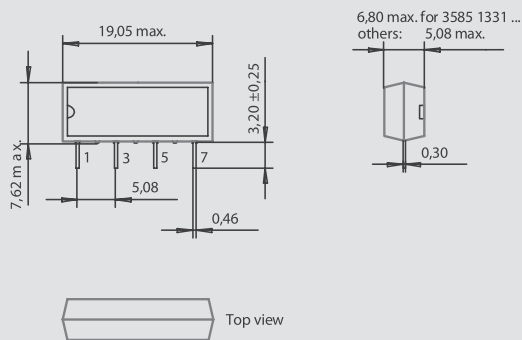

Dimensions in mm

Pull-in and Drop-out Voltage, Coil Resistance

The tolerances indicated are valid at 25 °C ± 3 °C. The temperature coefficient of the coil resistance is 0,4 % / °C.

Switching Voltage, Current and Capacity

The parameters as listed for switching voltage, current and capacity are maximum values. Exceeding any one of these values causes overload and reduces relay life expectancy.

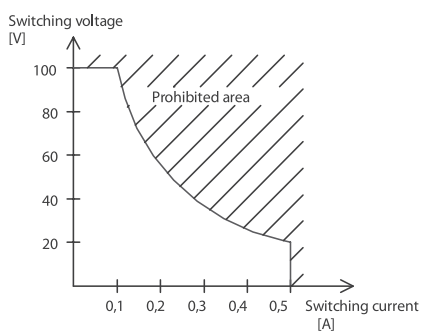

Contact Resistance

The contact resistance indicated is valid for new relays at nominal coil voltage.

The four-point method at 2 VDC / 100 mA or 10 mA is applied. Custom solutions for special applications, especially for switching signals smaller than 1 mV at 10 µA (low-level-applications) or applications requiring dynamic contact resistance measurement can be produced for special switching needs.

Temperature Range

The operating temperature of the relay is the equivalent of the internal temperature. If the relays are used in ambient temperatures (ϑ_a) higher than 20 °C, the maximum permissible operating voltage (U_T) must be calculated according to the table indicated below, using the formula:

$$U_T = U_{\max} \times k_1$$

(U_{\max} = max. permissible operating voltage)

ϑ_u (°C)	20	30	40	50	60	70
k_1	1,00	0,96	0,92	0,78	0,74	0,70

Switching Time

When using dry Reed Switches in relays, contact bounce may occur.

Pull-in time (incl. bounce time) at nominal voltage and 20 Hz typ. 0,5...1,8 ms

Drop-out time (with diode) at nominal voltage and 20 Hz typ. 0,5...1,5 ms

Comment

Relay versions with 15 V nominal coil voltage are available upon request.

REED RELAYS

Customer Specific DIL-REED RELAYS

Introduction

The customer specific Reed Relays are Dual-In-Line-Relays with standard housing height of 7,5 mm and a base area of 19 x 10 mm. These relays are potted with a permanent flexible plastic material subject to no mechanical force.

The advantage of the customer specific DIL-Reed Relays is that a wide variation of special pin configurations, contact arrangements and other applications can be realized. S.T.G. is thus able to produce the relay to meet special customer requirements.

Due to the small housing these relays can replace standard housing relays mounted on a PCB.

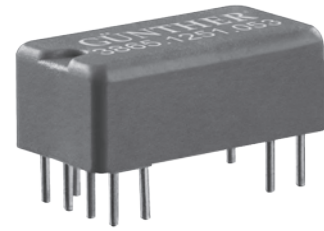

Version	Customer Specific Reed Relays in DIL-Housing	
Contact Form	1 Normally Open	2 Change Over
Type	3875 1342 ... ¹⁾	3865 1251 ... ¹⁾
Features	- High insulation resistance	- Industry-standard - Low input power

Coil Parameters

Nominal coil voltage	VDC	5	12	24	5	12	24
Pull-in voltage	max. VDC	3,8	9	18	3,8	9	18
Drop-out voltage	min. VDC	1	2	4	1	2	4
Operating voltage	max. VDC	12	20	40	7	16	30
Coil resistance	±10% Ω	320	1000	3200	100	500	2000

Contact Parameters

Switching capacity	max. W/VA	10	20
Switching voltage	max. V AC/DC	230	100
Switching current	max. A	0,5	1,0
Carrying current	max. A	1,0	2,0
Contact resistance	max. mΩ	150	150
Dielectric strength	min. VDC	400	200

Relay Parameters

Dielectric strength	coil/contact	VDC	4000	1000
Insulation resistance	coil/contact	Ω	10 ¹²	10 ¹⁰
Storage temperature		°C	-35...+100	-35...+100
Operating temperature		°C	-20...+80	-20...+80
Pull-in time incl. bounce time	max.	ms	1,0	1,5
Drop-out time with diode		ms	0,4	1,0
Dimensions		page	23	23
Weight		approx. g	2,3	3,2
Pin configuration (top view)				

1) Also available with diode

Customer Specific DIL-REED RELAYS

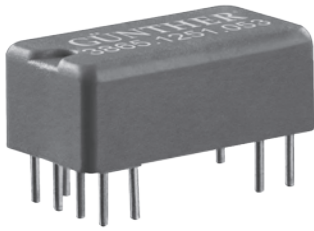

38..

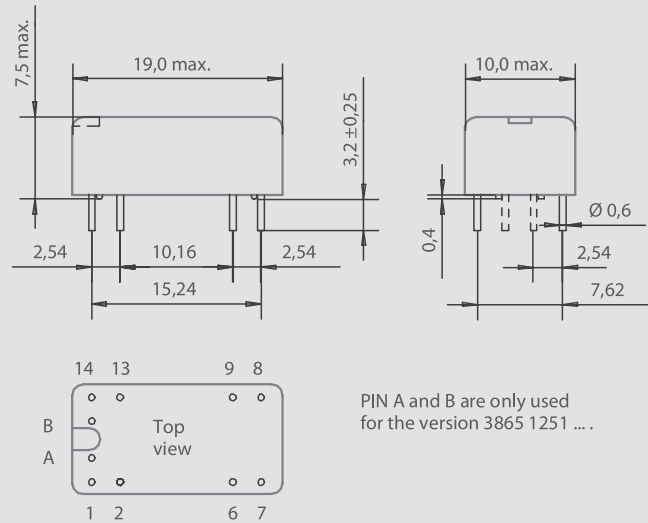

PIN A and B are only used for the version 3865 1251 ...

Dimensions in mm

UP ← for position sensitive versions

Pull-in and Drop-out Voltage, Coil Resistance

The tolerances indicated are valid at 25 °C ± 3 °C. The temperature coefficient of the coil resistance is 0,4 % / °C.

Switching Voltage, Current and Capacity

The parameters as listed for switching voltage, current and capacity are maximum values. Exceeding any one of these values causes overload and reduces relay life expectancy.

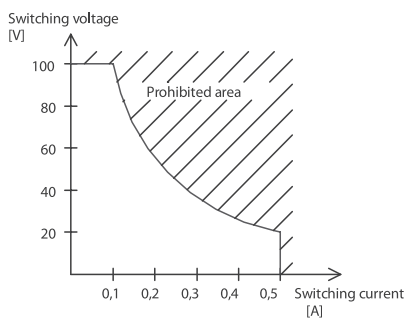

Contact Resistance

The contact resistance indicated is valid for new relays at nominal coil voltage. The four-point method at 2 VDC / 100 mA or 10 mA is applied.

Custom solutions for special applications, especially for switching signals smaller than 1 mV at 10 µA (low-level-applications) or applications requiring dynamic contact resistance measurement can be produced for special switching needs.

Temperature Range

The operating temperature of the relay is the equivalent of the internal temperature. If the relays are used in ambient temperatures (ϑ_a) higher than 20 °C, the maximum permissible operating voltage (U_T) must be calculated according to the table indicated below, using the formula:

$$U_T = U_{max} \times k_1$$

(U_{max} = max. permissible operating voltage)

ϑ_a (°C)	20	30	40	50	60	70
k_1	1,00	0,96	0,92	0,78	0,74	0,70

Order Example:

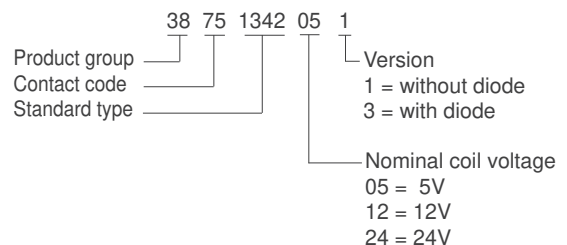

During and immediately after the soldering process no mechanical stress should occur on the soldering pins.

Customized special versions can be developed and manufactured pursuant to customer requirements.

PROXIMITY SENSORS

Type			4414	4414	4428	4428	4429	4429	4451	4451	4452	
Parameters			1525	1625	1525	1625	3823	0551	2725	0551	2325	
			121	121	111	111	111	111	311	311	311	
Contact Form			A	C	A	C	A	C	A	C	A	
Switching Capacity			W/VA	80	60	80	60	60	3	10	3	10
Switching Voltage			max. VAC	250	230	250	230	230	30	230	30	100
Switching Current			max. A	1,3	1,0	1,3	1,0	3,0	0,2	0,5	0,2	0,5
Carrying Current			max. A	2,0	2,0	2,0	2,0	4,0	0,5	1,0	0,5	1,0
Dielectric Strength			VDC	800	400	800	400	400	150	400	150	200
Contact Resistance			max. mΩ	80	100	80	100	80	100	100	100	150
Connecting Wire			2m LIYY	2 x 0,14	3 x 0,14	2 x 0,14	3 x 0,14	2 x 0,14	3 x 0,14	2 x 0,14	3 x 0,14	2 x 0,14
Recommended Magnet				4414	4414	4428	4428	4429	4429	4451	4451	4451
Operating Distance			mm	10 – 20	10 – 20	10 – 20	10 – 20	10 – 20	10 – 20	10 – 20	10 – 20	5 – 10
Operating Temperature			°C	-40 ... +150								
Housing Material				Polystyrol	Polystyrol	Polystyrol	Polystyrol	Polystyrol	Polystyrol	Polystyrol	Polystyrol	Polystyrol

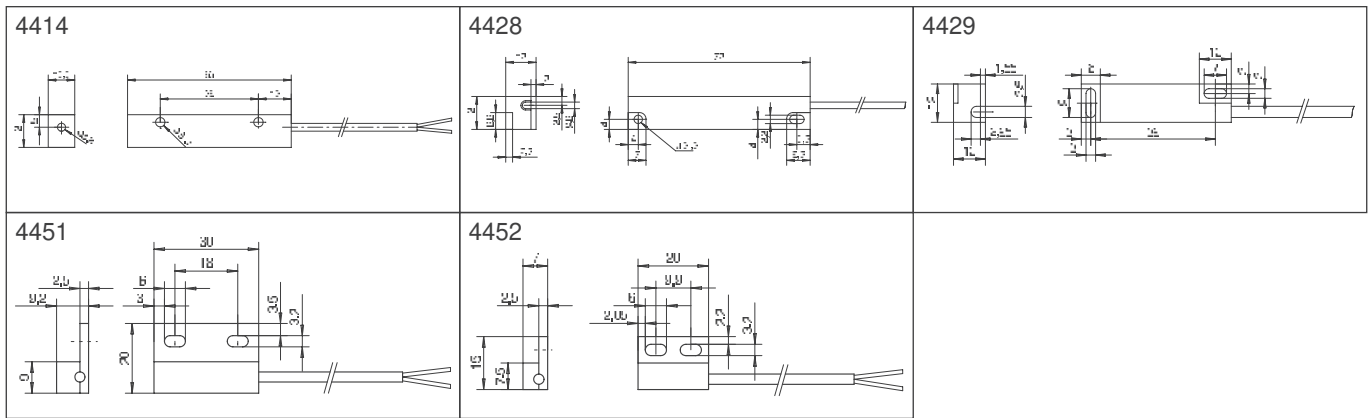

MAGNETS

Type	4414	4428	4429	4450	4452	4400	4400	4400	4400	4400
	0830	0830	0830	0624	0515	0515	0618	0630	0815	0830
	110	110	110	310	310	000	000	000	000	000
With Housing	o	o	o	o	o					
Housing Material	Polystyrol	Polystyrol	Polystyrol	Polystyrol	Polystyrol					
Plain						o	o	o	o	o
Magnet Material						Alnico				
Dimensions in mm	See below					5x15	6x18	6x30	8x15	8x30

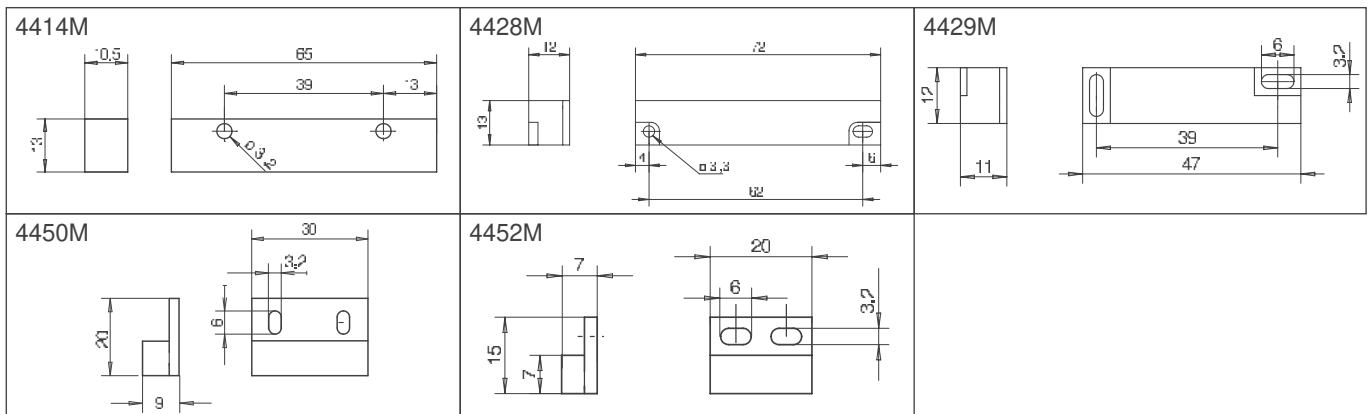

Parameters	Type	4426	4426	4432	4433	4433	4415	4415	4412
		2325	0551	2725	2725	0551	2325	0551	3823
		121	121	321	321	321	321	321	021
Contact Form		A	C	A	A	C	A	C	A
Switching Capacity	W/VA	10	3	10	10	3	10	3	60
Switching Voltage	max. VAC	100	30	230	230	30	100	30	230
Switching Current	max. A	0,5	0,2	0,5	0,5	0,2	0,5	0,2	3,0
Carrying Current	max. A	1,0	0,5	1,0	1,0	0,5	1,0	0,5	4,0
Dielectric Strength	VDC	200	150	400	400	150	200	150	400
Contact Resistance	max. mΩ	150	100	100	100	100	150	100	80
Connecting Wire	2m LIYY	2 x 0,14	3 x 0,14	2 x 0,14	2 x 0,14	3 x 0,14	2 x 0,14	3 x 0,14	3 x 0,75
Recommended Magnet		6x18	6x18	8x30	8x30	8x30	8x30	8x30	11.2
Operating Distance	mm	5 – 20	5 – 20	10 – 20	10 – 20	10 – 20	10 – 20	10 – 20	5 – 20
Operating Temperature	°C	- 40... + 150							
Housing Material		Polystyrol	Polystyrol	Polystyrol	Polystyrol	Polystyrol	Polystyrol	Polystyrol	Alu

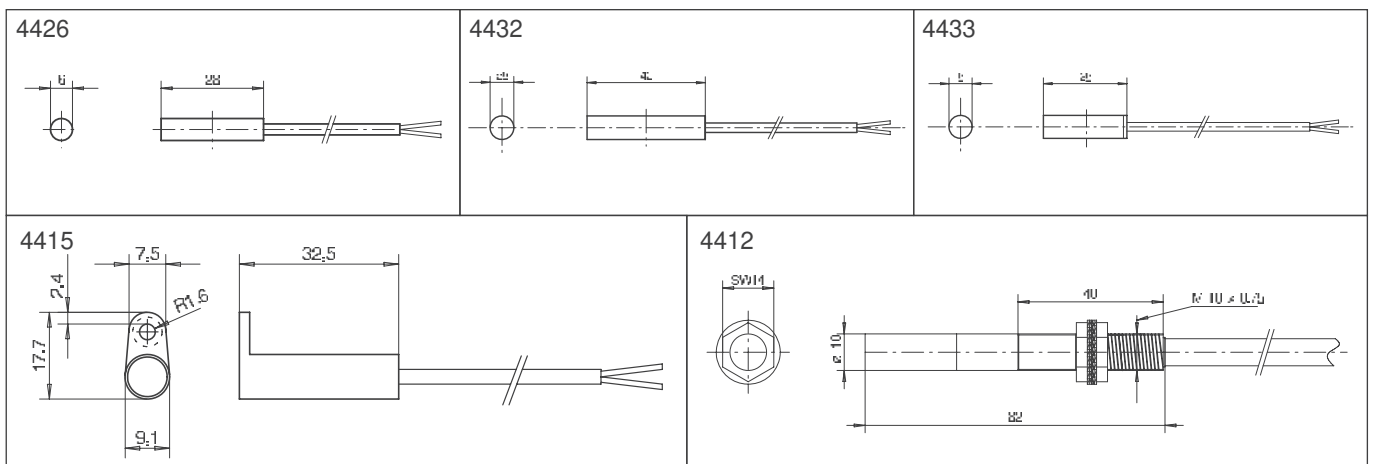

Blue is our standard colour for the highly shock-resistant polystyrene housing. Customized colours - clear, white, and brown - can be specially ordered. Standard cable length: 1m

Ordering Information:

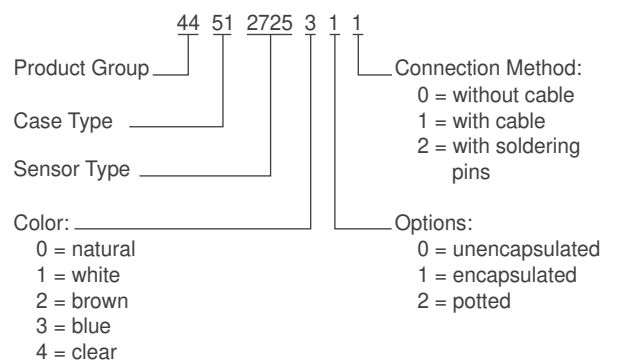

SENSOR INCLINATION / ACCELERATION, DAMPENED

PRODUCT DESCRIPTION

- Precision tilt or pendulum switch / sensor
- Applicable as e.g. acceleration sensor
- Variable switching angle depending on installation
- Hg-free
- Suitable to be soldered

APPLICATION

Different applications, when an exact switching angle is required. The inclination setting can be adjusted directly on the circuit board or application. The oil damping makes the sensor insensitive to vibrations.



TECHNICAL DATA

Function	Contact arrangement	1 FA / NO
	Contact material	Rh
	Min. differential switching angle	[°] 3
Electrical data		
Max. switching voltage	[V]	100
Max. switching current	[mA]	400
Max. carrying current	[mA]	1000
Max. switching capacity	[W/VA]	10
Max. contact resistance	[mOhm]	300
Min. insulation resistance	[Ohm]	10 ⁹
Ambient conditions		
Operating temperature range	[°C]	-40...+125
Other features		
Weight (approx.)	[g]	5

ORDER NUMBER

5601.2003.201 (standard type)

ACCESSORIES & SPECIALS

Sensor with connecting cords
We assist you with difficult applications!

DIMENSIONS

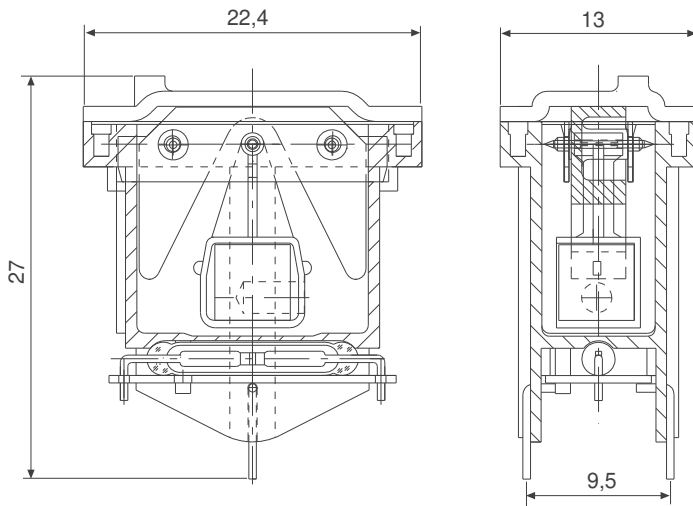

FUNCTION

Tilt Switch:
At a specific angle, the reed switch is activated. By changing the position of the sensor on the object, the switching angle can be changed.

Acceleration sensor:
Acceleration will activate the pendulum. The switching activating point corresponds to a specific deflection β and thus to a specific acceleration. The acceleration can be calculated according to the following formula:

$$a = \tan\beta * g$$

If the switching angle at a specific acceleration is needed, the following formula is applicable:

$$\beta = \arctan a * g$$

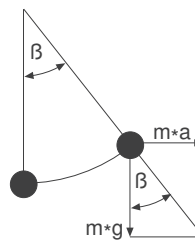

β = Switching angle
 a = Acceleration
 g = Gravity acceleration (9,81 m/s²)

RELATION ACCELERATION / ANGLE

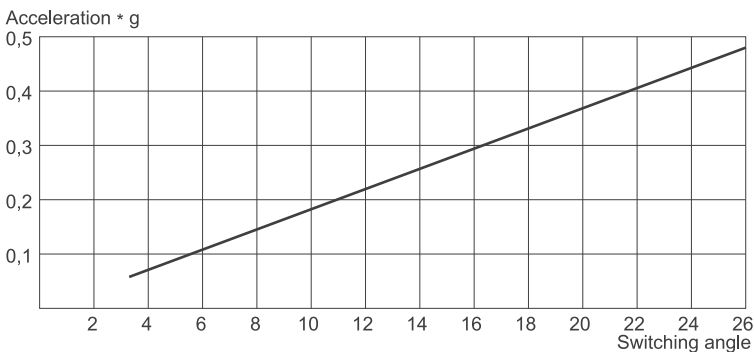

PLEASE NOTE:

The inclination of the object influences the acceleration!

The sensor is filled with silicon oil!

Original size

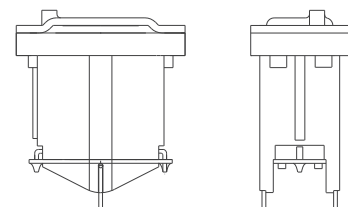

SENSOR INCLINATION / ACCELERATION

PRODUCT DESCRIPTION

- Precision tilt or pendulum sensor
- Applicable as e.g. acceleration sensor
- Variable switching angle depending on installation
- Hg-free
- Suitable to be soldered



APPLICATION

Different applications, when an exact switching angle is required. The inclination setting can be adjusted directly on the circuit board or application.

TECHNICAL DATA

Function		
Contact arrangement		1 FA / NO
Contact material		Rh
Min. differential switching angles		[°] 3
Electrical data		
Max. switching voltage	[V]	100
Max. switching current	[mA]	400
Max. carrying current	[mA]	1000
Max. switching capacity	[W/VA]	10
Max. contact resistance	[mOhm]	300
Min. insulation resistance	[Ohm]	10 ⁹
Ambient conditions		
Operating temperature range	[°C]	-40...+125
Other features		
Weight (approx.)	[g]	2

ORDER NUMBER

5601.2001.223 (standard type)

ACCESSORIES & SPECIALS

Sensor with connecting cords.
We assist you with difficult applications.

DIMENSIONS

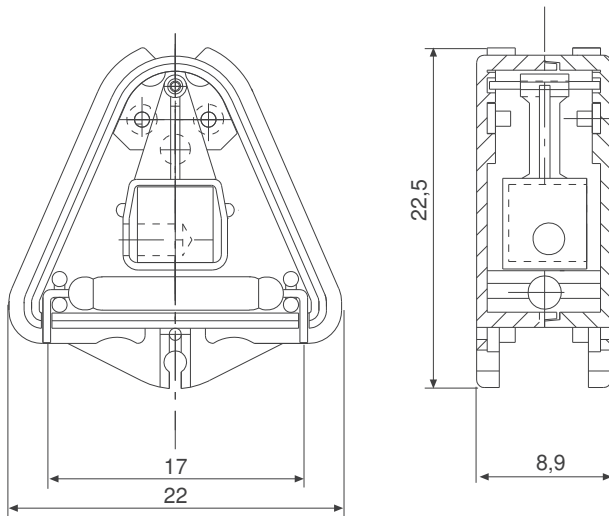

FUNCTION

Tilt Switch:

At a specific angle, the reed switch is activated. By changing the position of the sensor on the object, the switching angle can be changed.

Acceleration sensor:

Acceleration will activate the pendulum. The switching activating point corresponds to a specific deflection β and thus to a specific acceleration. The acceleration can be calculated according to the following formula:

$$a = \tan\beta * g$$

If the switching angle at a specific acceleration is needed, the following formula is applicable:

$$\beta = \arctan a * g$$

β = Switching angle
 a = Acceleration
 g = Gravity acceleration (9,81 m/s²)

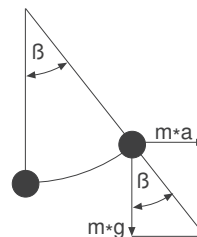

RELATION ACCELERATION / ANGLE

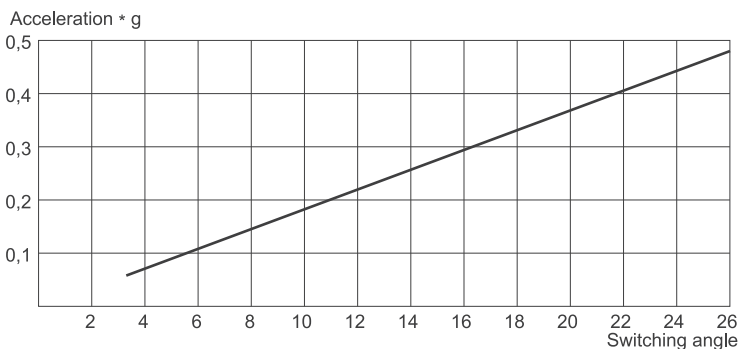

PLEASE NOTE:

The inclination of the object influences the acceleration!
In case of vibrations, faults may occur!

Original size

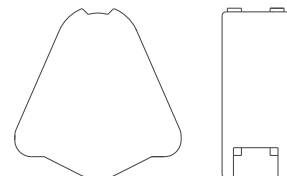



S.T.G. GERMANY GMBH

Andernacher Str. 10
D-90411 Nürnberg Germany
Telefon: +49 (0) 911 6552-0
Fax +49 (0) 911 6552-239
schuster@stg-germany.org
www.stg-germany.de



S.C. S.T.G. Switch Technology Gunther S.R.L.

Gheorghe Baritiu Str. 30 515400
Blaj / Alba
Romania
Telefon: +40 786 096 683
aurora@stg-germany.org
www.stg-germany.de

